

metos

RANGE

FUTURA RP2, RP4, RP6

Installation and Operation Manual

Translation of the original documentation



Rev. 5.2
(4.1.2023)

3494319, 3494358, 3494397, 3521114, 3521115, 3521121, 3521153, 3521178, 3521386, 3521393, 3521467, 3572214, 3572221, 3755004, 3755005, 3755027, 3755028, 4210002, 4210004, 4210450, 4210454, 4210458, 4210460, 4210478, 4210480

- 1. General 3**
- 1.1. Symbols used in the manual 3
- 1.2. Symbols used on the appliance 3
- 1.3. Checking the relationship of the appliance and the manual 3
- 2. Safety 4**
- 2.1. Safe use of the appliance 4
- 2.1.1. Disposal of the appliance 4
- 3. Functional description 4**
- 3.1. Intended use of the appliance 4
- 3.1.1. Use for other purposes 4
- 3.2. Operating principle and construction 4
- 4. Operation instructions 5**
- 4.1. Before using the appliance 5
- 4.1.1. Selecting cookware 5
- 4.2. Using the range 5
- 4.3. After use 6
- 4.3.1. Cleaning 6
- 4.3.2. Other service measures 7
- 5. Installation 7**
- 5.1. General 7
- 5.2. Transporting and unpacking the appliance 7
- 5.3. Positioning the range 7
- 5.4. Electrical connections 7
- 5.5. Test-run 8
- 6. Troubleshooting 8**
- 7. Technical specifications 9**

1. General

Carefully read the instructions in this manual as they contain important information regarding proper, efficient and safe installation, use and maintenance of the appliance.

Keep this manual in a safe place for eventual use by other operators of the appliance.

The installation of this appliance must be carried out in accordance with the manufacturer's instructions and following local regulations. The connection of the appliance to the electric and water supply must be carried out by qualified persons only.

Persons using this appliance should be specifically trained in its operation.

Switch off the appliance in case of failure or malfunction. Have the appliance serviced by a technically qualified person authorized by the manufacturer and using original spare parts.

Not complying with the above may put the safety of the appliance in danger.

1.1. Symbols used in the manual



This symbol informs about a situation where a safety risk might be at hand. Given instructions are mandatory in order to prevent injury.



This symbol informs about the right way to perform in order to prevent bad results, appliance damage or hazardous situations.



This symbol informs about recommendations and hints that help to get the best performance out of the appliance.

1.2. Symbols used on the appliance



This symbol on a part informs about electrical terminals behind the part. The removal of the part must be carried out by qualified persons only.

1.3. Checking the relationship of the appliance and the manual

The rating plate of the appliance indicates the serial number of the appliance. If the manuals are missing, it is possible to order new ones from the manufacturer or the local representative. When ordering new manuals it is essential to quote the serial number shown on the rating plate.

2. Safety

2.1. Safe use of the appliance



Because the range is a heated appliance that has hot surfaces during normal use, the following warnings and instructions must be followed in order to avoid burns.

During long-time operation even the frame surrounding the cooking plates gets hot.

The capability of the cooking plates to store and even out the heat also keeps them hot for a long time after switching them off.

For safe handling of cookware on the cooking top, always use heat protective gloves.

Do not leave the range on for long periods totally without supervision.

2.1.1. Disposal of the appliance

Once the appliance has reached the end of its useful life, it must be disposed of in compliance with local rules and regulations. The appliance may contain substances/materials which potentially have an adverse impact on the environment as well as recyclable materials. The best way of dealing with such substances is to dispose of them through a proper waste company

3. Functional description

3.1. Intended use of the appliance

The Futura -range is intended for preparing different kinds of foodstuffs using cookware.

3.1.1. Use for other purposes



Use of the appliance for any other purposes than that mentioned above is prohibited.

Preparing food directly on the cooking plate without cookware is prohibited.

Covering the gaps between the range cooking plates and the upper frame with folio is prohibited



The manufacturer shall not be held liable for any situations which may arise from failure to comply with the warnings and instructions given in this manual.

3.2. Operating principle and construction

Depending on the model, the range is equipped with two, four or six cooking plates.

Each cooking plate is equipped with a 7-position power regulator which allows power regulation in several steps. A green pilot light for every cooking plate indicates that the plate is on.

In order to ease daily cleaning the cooking plates are hinged and can be swung up in an upright position. In addition, the range is equipped with a removable spillage tray.

4. Operation instructions

4.1. Before using the appliance



Using the appliance for the first time or when heating elements or cooking plates have been changed, turn on plates and ovens at MINIMUM temperature for SEVERAL hours or until the insulation resistance is OK. This allows remaining humidity in the heating elements and cooking plates to dry up. In fact, on first connection, the earth insulation can be relatively inadequate, but after the above-mentioned initialization run the insulation level will normally be re-established according to CEI 18-6 part 307 regulations.



Setting the power or temperature to maximum right away at first run may damage the heating elements or the cooking plates.

In unclear cases contact our technical support:
technical.support@metos.com



The cooking plates of the range are protected with a thin layer of oil for the duration of storage and transportation. When heating up the range for the first time the oil may create some smoke and unpleasant smell. This is quite normal and disappears quickly when using the range.

4.1.1. Selecting cookware

Always use flat-based cookware in order to achieve good heat transfer and to increase the service life of the cooking plate. Placing a cold and wet pan on a red-hot cooking plate should be avoided as the thermal tensions created considerably decrease the service life of the plate.

You get the best benefit from the range as well as from the cookware by observing the following:

- Use good quality flat-based cookware.
- Wait for pans to cool before putting them in cold water.
- Always ensure pans have clean, dry bases before use.
- Ensure pan handles are positioned safely and away from heat sources.
- Always use pan lids except when frying.
- Remember good quality pans retain heat well, so generally only low or medium heat is necessary.

4.2. Using the range



Switch the appliance off if it is damaged or is malfunctioning. Contact authorised service personnel using original spare parts for service of the appliance.



Ranges intended for use aboard ships are equipped with a potrack. Using a range aboard a ship without the potrack is prohibited.

During the installation, a mains switch may have been fitted near the range, often on a wall nearby. Check that the mains switch is in the ON position.

The range is controlled with power regulators and pilot lights.

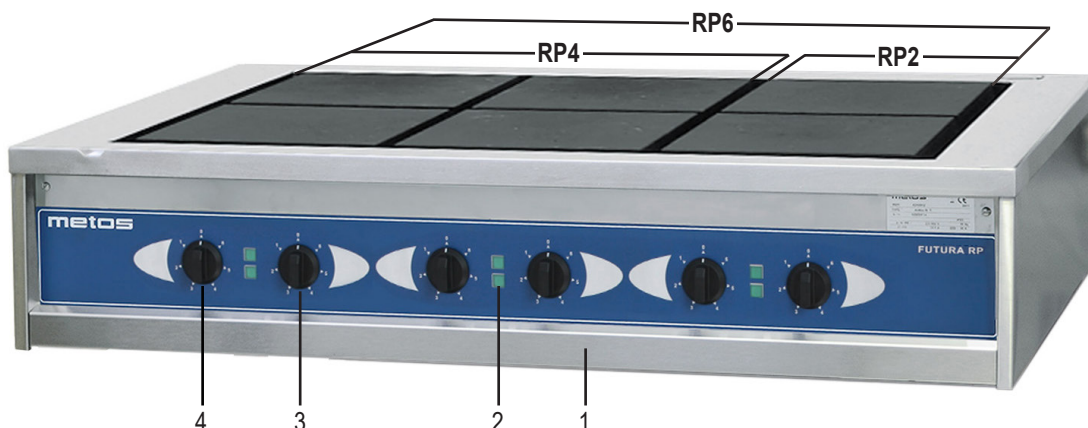

Operating panel

- 1. Spillage tray
- 2. Pilot light cooking plate
- 3. Power regulator front plate
- 4. Power regulator, rear plate

Each cooking plate is equipped with a 7-position power regulator which allows powerregulation in several steps. A green pilot light for every cooking plate indicates that the plate is on.

Cooking is started by turning the power regulator to position 6. When boiling starts, the power is decreased as needed. Usually it is possible to use a small or medium power setting.



Do not leave the cooking plate on without any load, because it then overheats, which considerably decreases the service life of the plate. By turning the cooking plate off when not needed, energy is saved and a cooler working environment is achieved.



If there are longer interruptions in the electricity distribution, all power regulators of therange should be set to the 0 position. This should be done in order to prevent unexpectedstart-up of the range when the electricity distribution is restored.

4.3. After use

4.3.1. Cleaning



Use of a water hose or pressure cleaning jet is strictly forbidden.



It is not allowed to wipe the undersides of cooking plates swung up to a cleaning position with a wet sponge, cloth etc., because water flowing down the plate is absorbed into the insulating material thus causing earth leakage.



When cleaning the cooking plates, observe that they are hot a long time after they have been switched off. When the cooking plates are swung up for cleaning, it is advisable to support the plate in the upper position with one hand thus preventing the possibility that they unexpectedly return to their working position.



Be careful when removing the spillage tray, as it may contain spillages that are still hot.

Cleaning is very easy, if possible spillovers are removed immediately with a damp cloth. Sugar and mixes containing much sugar must be removed immediately, because later removing is laborious.

In all cleaning, prefer chemical cleaning methods rather than mechanical rubbing. Use a slightly alkaline detergent (pH 8-10) diluted in water according to instructions when cleaning the surfaces of the range.



Always dry the cooking plates after cleaning by heating them up.

Clean cooking plates give an efficient heat transfer to the cookware. Cooking is then faster and the service life of the cooking plates is extended.

The spillage tray is pulled out and cleaned. Outer surfaces are wiped off with a damp cloth and then wiped dry.

4.3.2. Other service measures



The appliance does not include any user serviceable parts inside. Service must be left to authorised service personnel.

5. Installation

5.1. General

The installation of this appliance must be carried out in accordance with the manufacturer's instructions and in compliance with local rules and regulations. These instructions must be used together with the installation drawing.



The connection of the appliance to the electric supply must be carried out by qualified persons only.

5.2. Transporting and unpacking the appliance

The best way to move the range is to keep it in its package as long as possible while it also protects the range from outer damage. If it is necessary to unpack the range, possible lifting must be done from the bottom frame using suitable spacers of wood. In order to avoid damages it is not allowed to use the cooking top as a workbench during installation.

5.3. Positioning the range



Because the temperature of a cooking plate accidentally forgotten on without a pan may reach even 550°C, it is mandatory to follow local fire safety regulations when installing the range.

The range is positioned in the installation place and adjusted in a horizontal position from the adjustable legs.



When the range is on the correct location and in a horizontal position, it must be bolted to the floor, the land models by the flanges in the rear adjusting legs and the marine models from all four leg flanges.

5.4. Electrical connections



Besides the live electrical parts, also look out for possible moving mechanisms inside the appliance, if there is a need for testing during installation and the guards or cover plates are detached.



In order to make eventual future service easier and increase safety, a mains switch must be installed near the appliance. This switch must disconnect the appliance completely from the electrical supply network.

The input of the power cable is at the bottom of the stove, in the right front corner. The connection point for the input cable can be found behind the right side panel. The right side panel must be removed.

Take into account the adjustment movement of the stove (200 mm) when installing the supply cable if the stove is equipped with height adjustment.

5.5. Test-run



Please read the safety and operation instructions as well as the functional description before testing the range. The appliances under the cooking top are provided with their own manuals.

Test the range once it has been connected to the mains electricity.

Check that

- every cooking plate heats up and the corresponding pilot light turns on when the plate is switched on with the power regulator
- no wires inside the appliance get jammed before refitting the side panel.

Refit the side panel.

6. Troubleshooting

If the appliance fails to work, check to ensure that:

- the plug is connected to the outlet
- it has been used according to instructions
- all removable parts are in place
- the disconnection switch (usually on a wall or in the immediate vicinity of the oven) is in the ON position
- That the circuit breakers (fuses) of the appliance in the electricity distribution board are working order. Ask an authorised person to check the circuit breakers.

Should the range still not work, contact an authorised agent. Before making the call, make sure you have at hand the appliance type and serial number to be found on the name plate.



This appliance does not contain parts which can be serviced by the user. Maintenance must be carried out by qualified persons only.

7. Technical specifications

- 81848-83D Wiring diagram RP2-RP6 3/N/PE 380-415V/220-240V, 3/PE 220-230V
- 81849D83 Wiring diagram RP2-RP6 3/PE 380-440V
- T03431C3 Wiring diagram RP2-RP6 2,5kW 3/PE 480V
- T03519D3 Wiring diagram RP2S-RP6S 4kW 3/PE 440V
- S00092B4 Wiring diagram adjustable stand RP / Ardox 3/N/PE
380-415V/220-240V, 3/PE 220-230V, 3/PE 380-440V
- T02237B3 Installation drawing RP2
- T02238B3 Installation drawing RP4
- T02239B3 Installation drawing RP6
- T02240A3 Installation drawing RP2 with height adjust
- T02241A3 Installation drawing RP4 with height adjust
- T02242A3 Installation drawing RP6 with height adjust

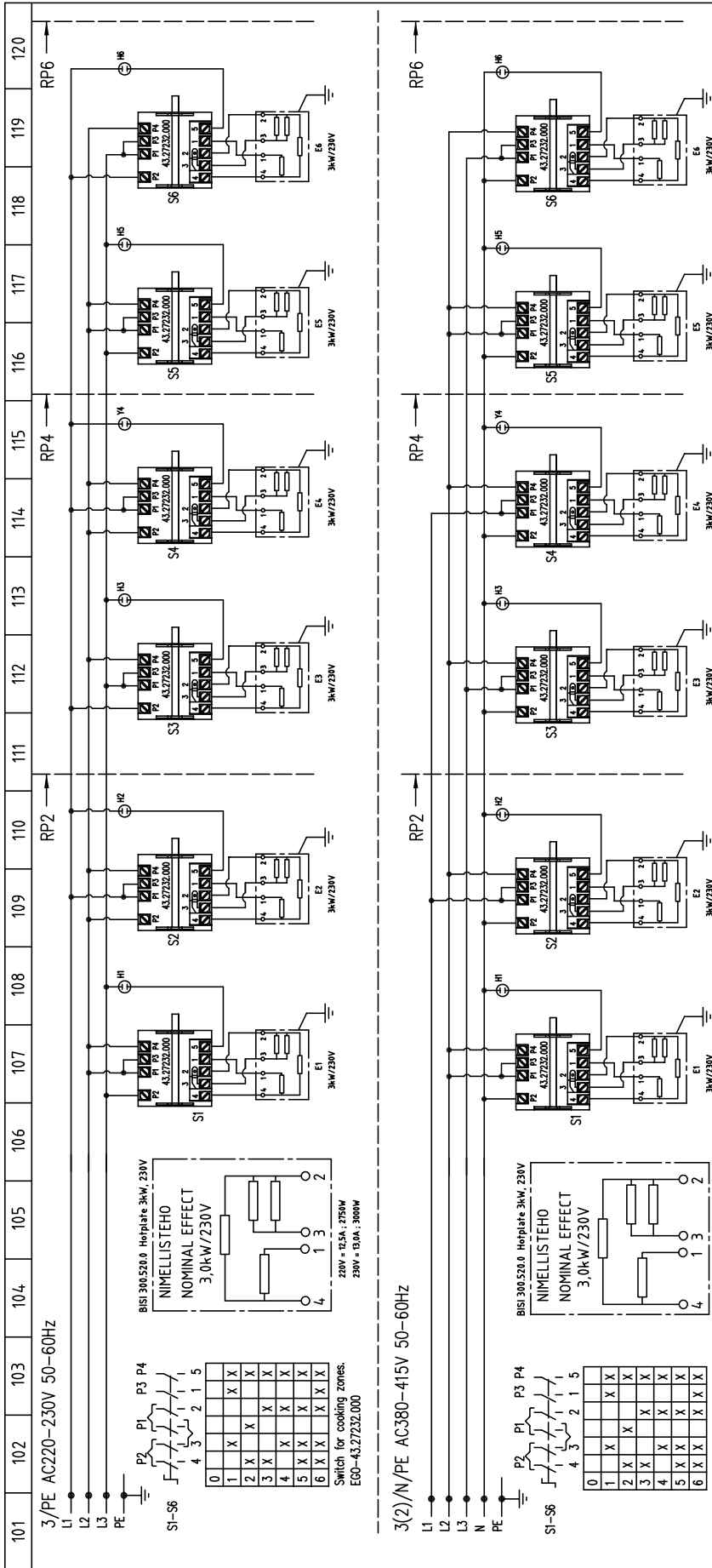

LIITÄNTÄTIEDOT/CONNECTION INFORMATION

VERKKO / ELECTRIC SUPPLY	RP2			RP4			RP6		
	P/A/W	I/A	P/A/W	I/A	P/A/W	I/A	P/A/W	I/A	
3/PE AC220V 50-60Hz	5,5	22	11,0	34	16,5	43			
3/PE AC230V 50Hz	6,0	23	12,0	35	18,0	45			
2/N/PE AC380V 50Hz	5,5	13							
2/N/PE AC400V 50Hz	6,0	13							
2/N/PE AC415V 60Hz	6,5	14							
3/N/PE AC380V 50Hz			11,0	25	16,5	25			
3/N/PE AC400V 50Hz			12,0	26	18,0	26			
3/N/PE AC415V 50Hz			13,1	27	19,6	27			

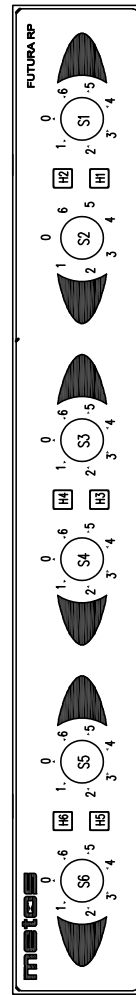

Pää- ja ohjauvirtapiirin kytkentäkaavio
Kopplingschema 3(2)/N/PE AC380-415/220-240V 50Hz
Main- and control circuit diagram 3/PE AC220-230 50-60Hz

Metos Futura
RP-liesi ; spis ; range

Rev.	Mtuutos	26.02.2020	A.O.
TEK.	DESIGN	26.02.2020/A.O.	
TEK.	CMO		
HY.	APR		
Proj.	81848-83D		
DWG NR	81848-83D		

81848-83D Wiring diagram RP2-RP6 3/N/PE 380-415V/220-240V, 3/PE 220-230V

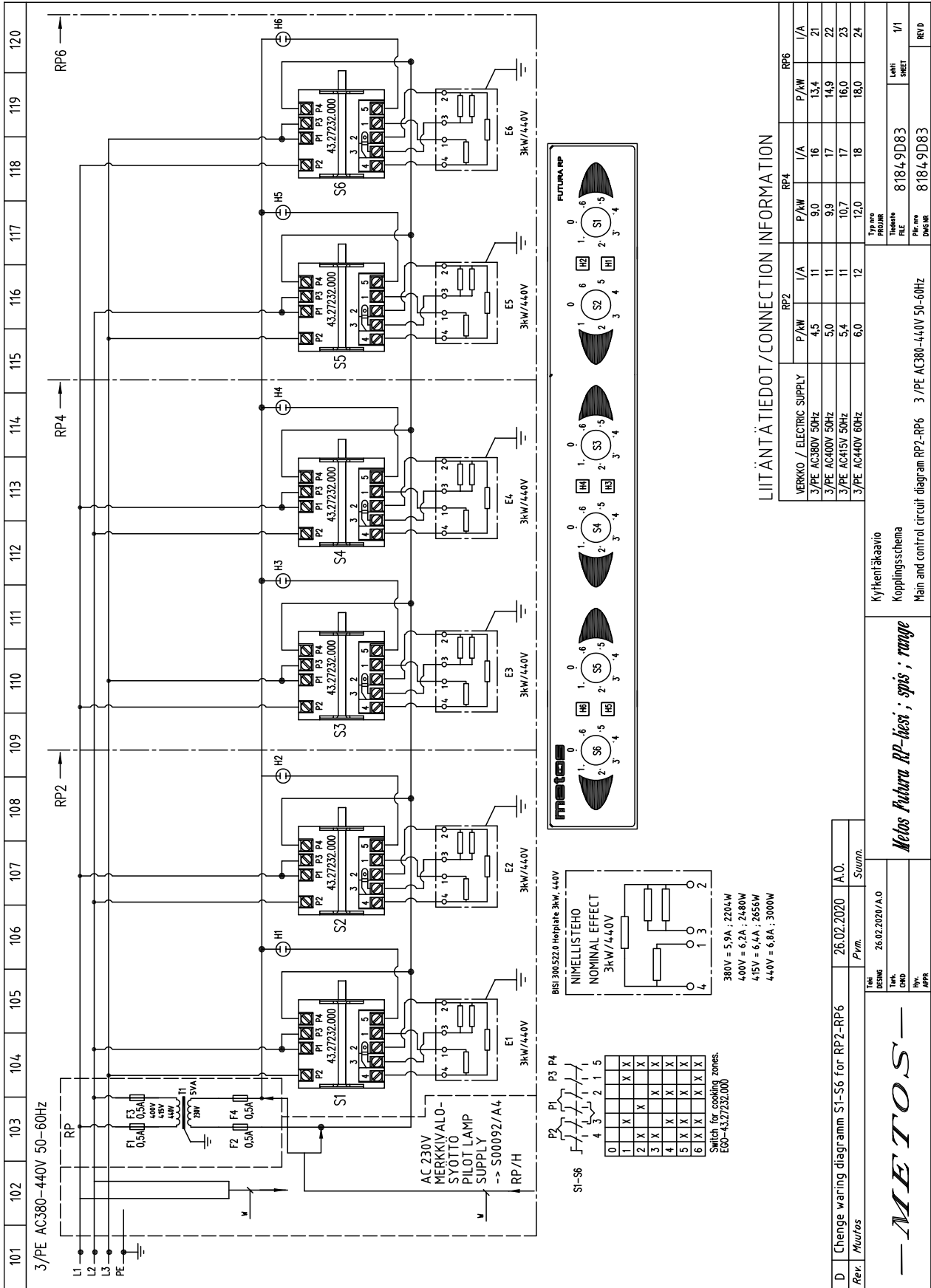

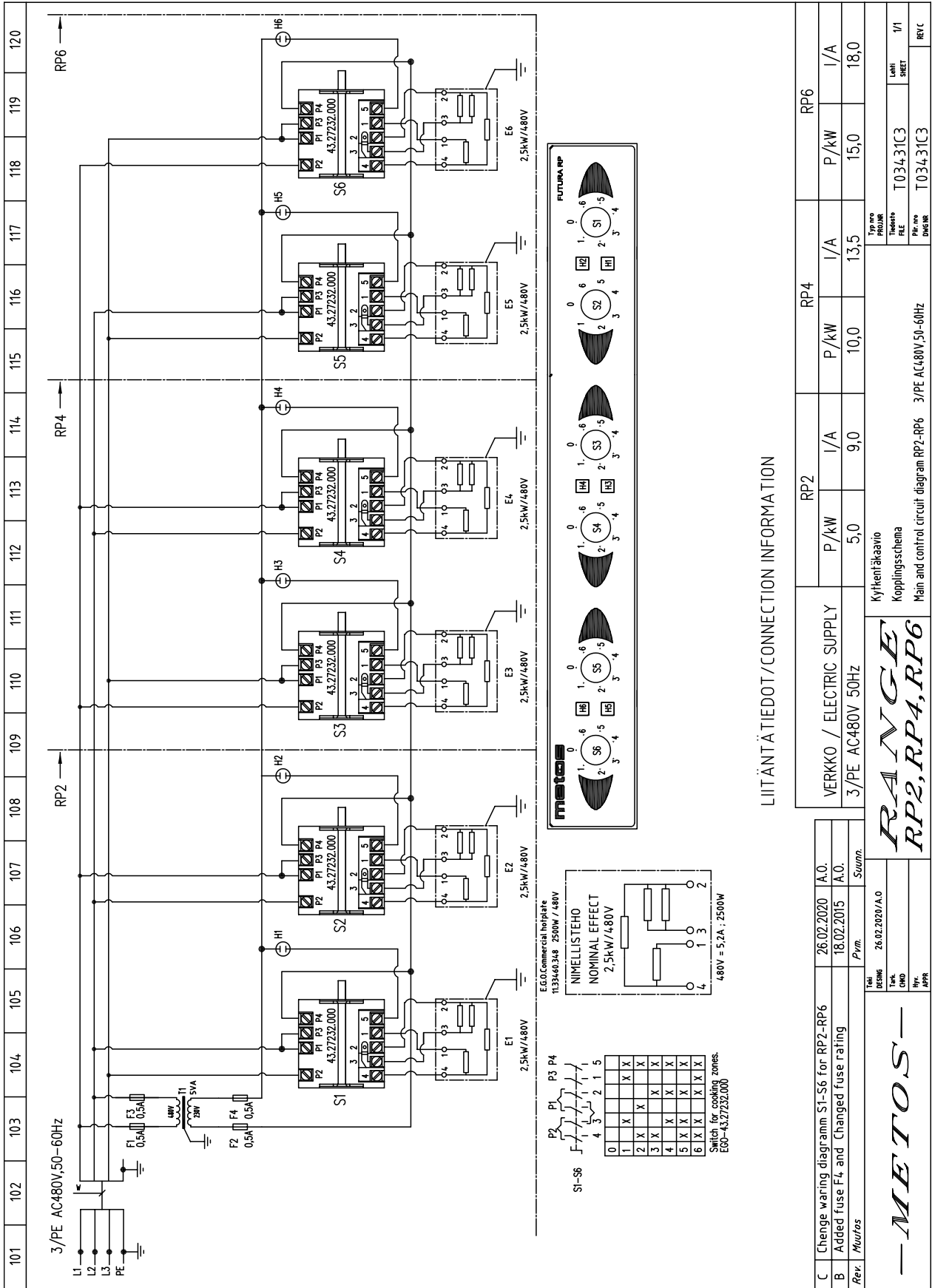

T03431C3 Wiring diagram RP2-RP6 2,5kW 3/PE 480V

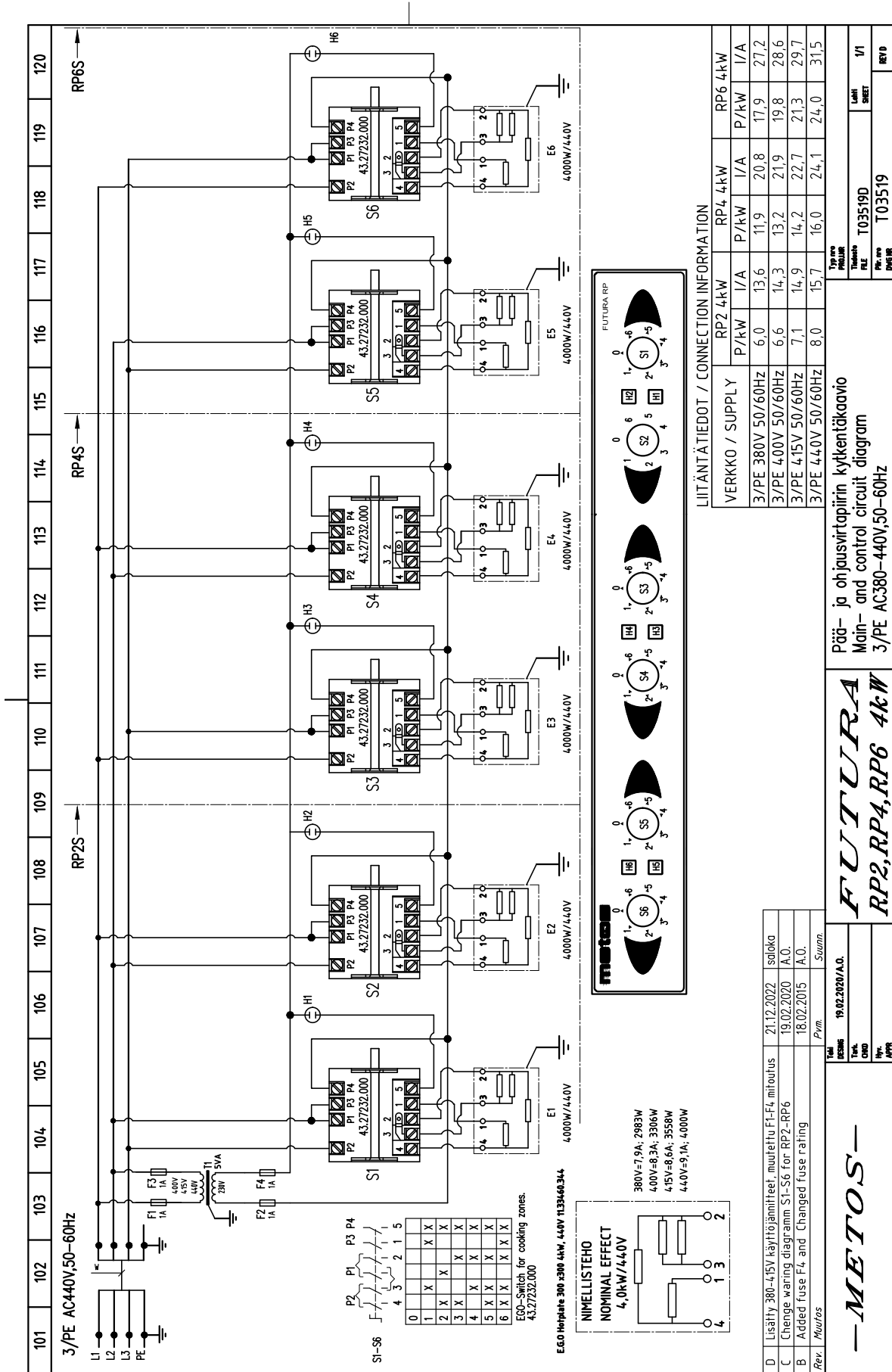

T03519D3 Wiring diagram RP2S-RP6S 4kW 3/PE 440V

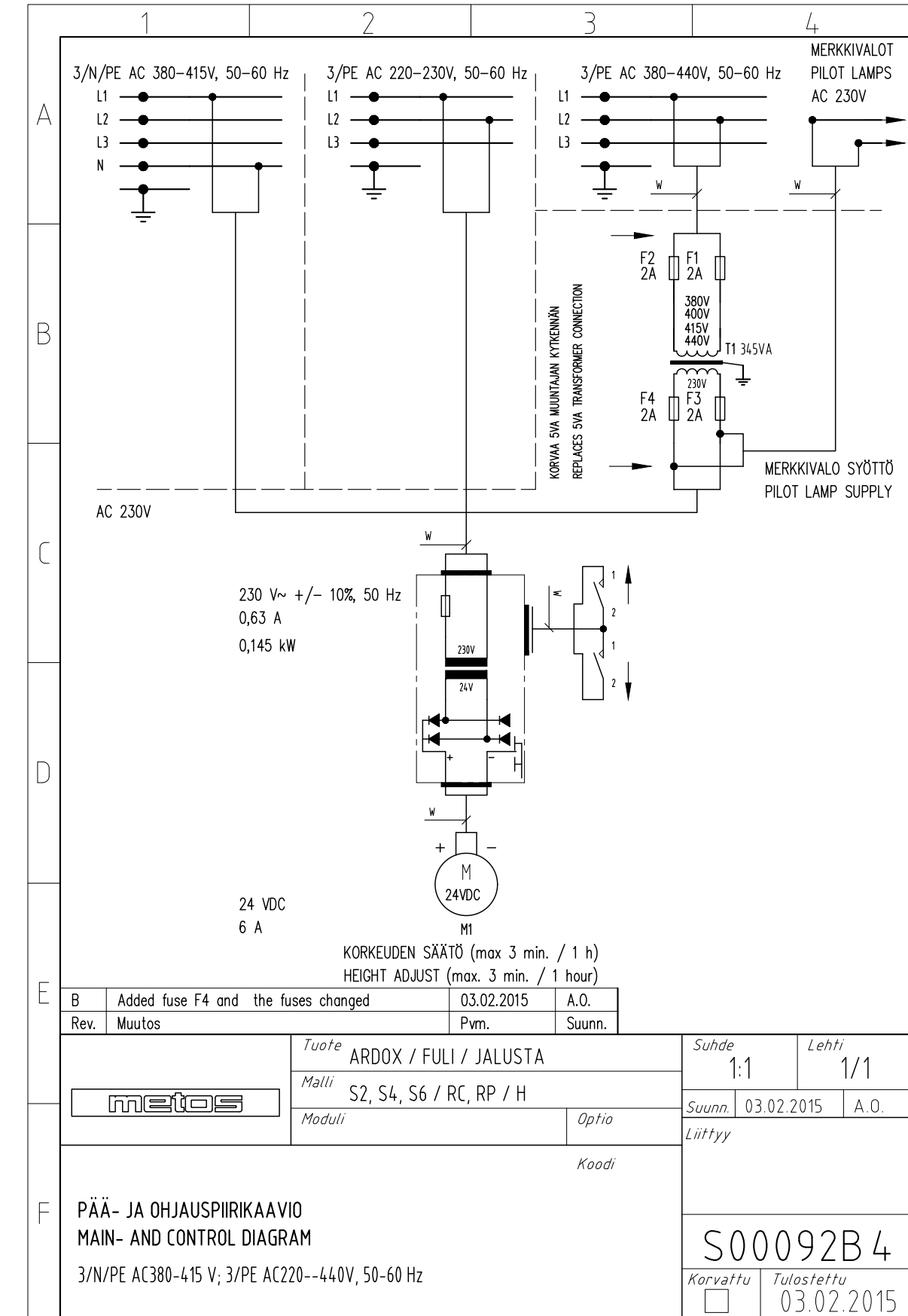

S00092B4 Wiring diagram adjustable stand RP / Ardox 3/N/PE 380-415V/220- 240V, 3/PE 220-230V, 3/PE 380-440V

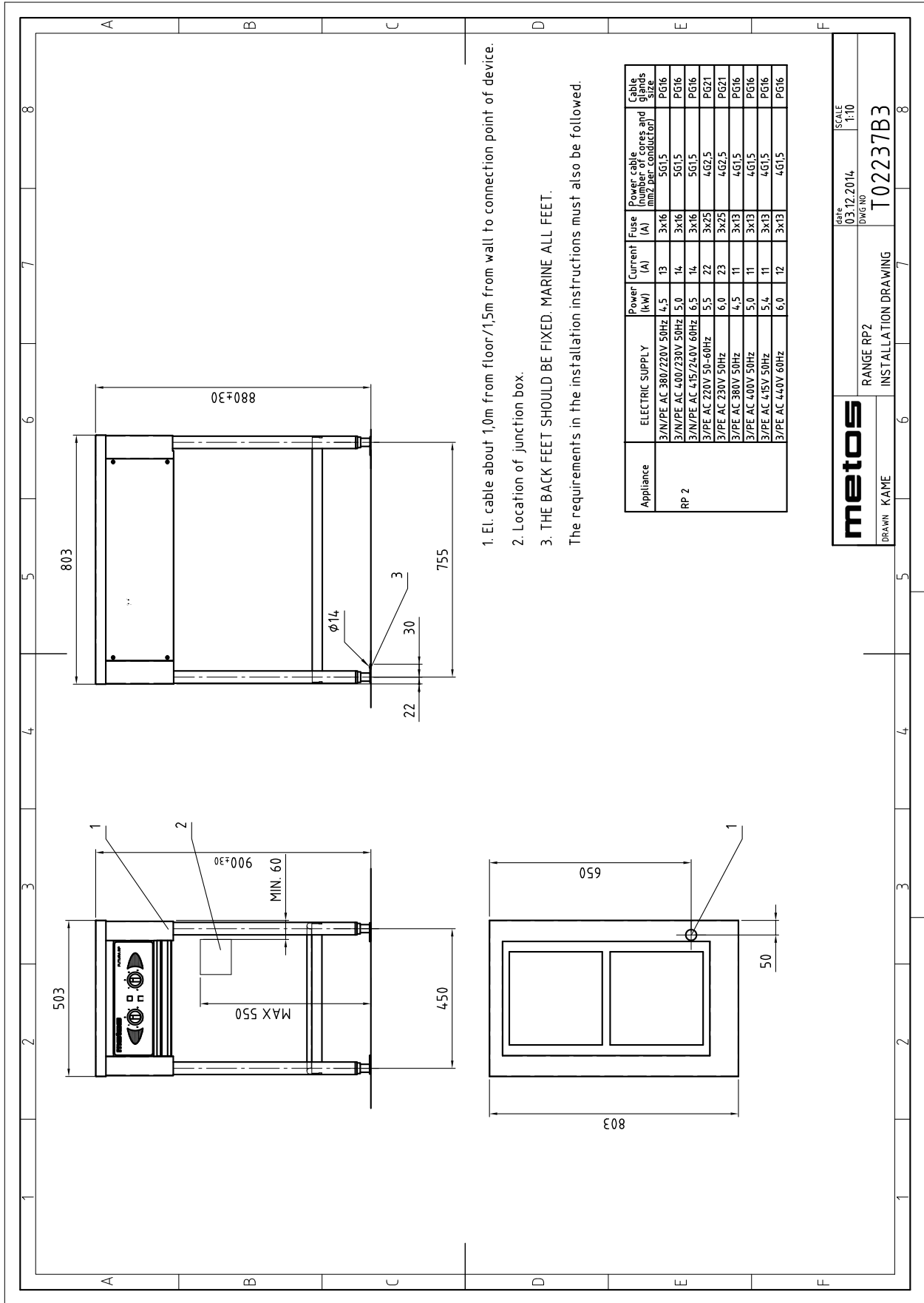

T02237B3 Installationsritning RP2

metos
 RANGE RP2
 INSTALLATION DRAWING
 DRAWN: KAME

date: 03.12.2014
 DWG NO: T02237B3
 SCALE: 1:10

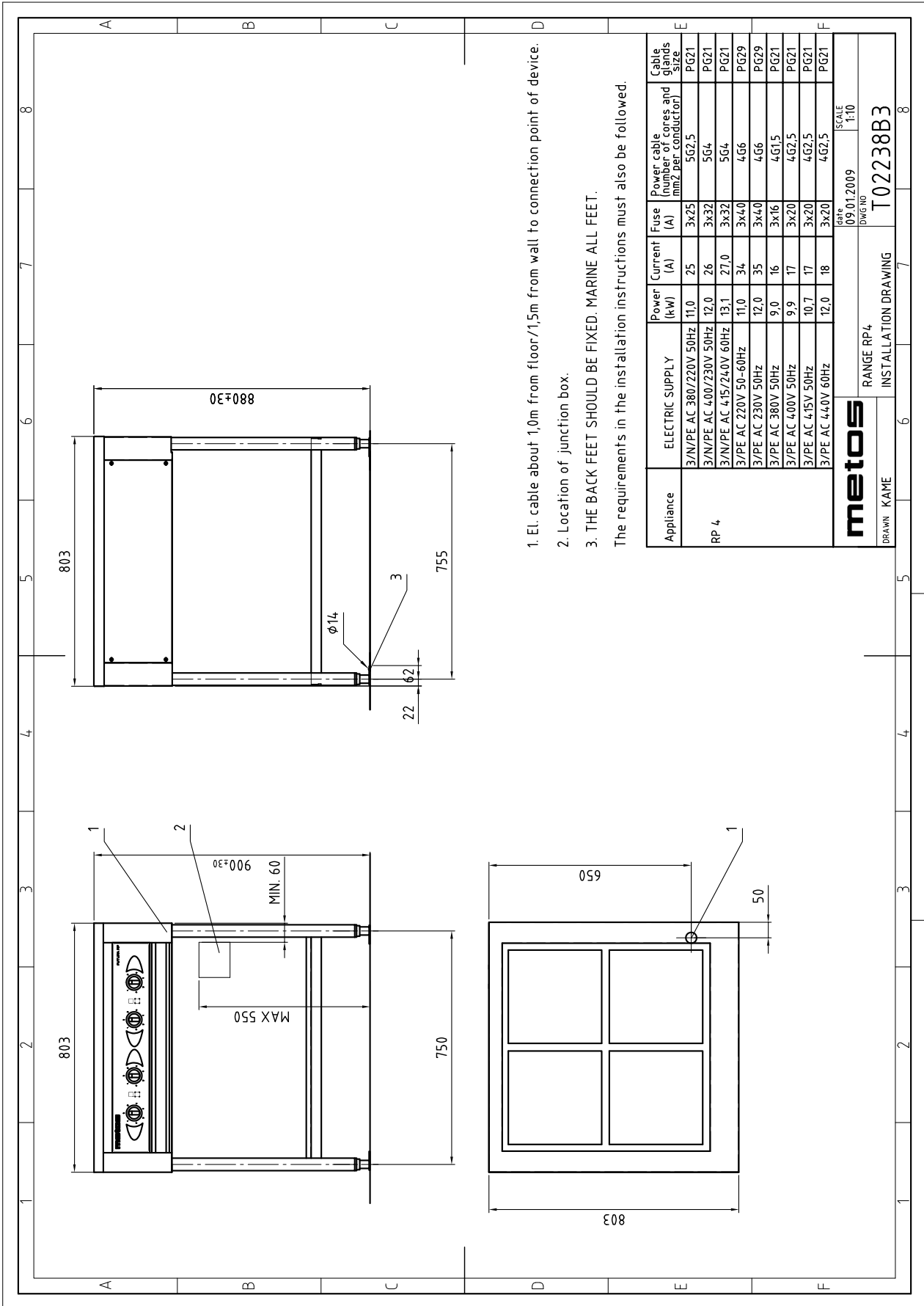

1. El. cable about 1,0m from floor/1,5m from wall to connection point of device.
 2. Location of junction box.
 3. THE BACK FEET SHOULD BE FIXED. MARINE ALL FEET.
- The requirements in the installation instructions must also be followed.

T02238B3 Installationsritning RP4

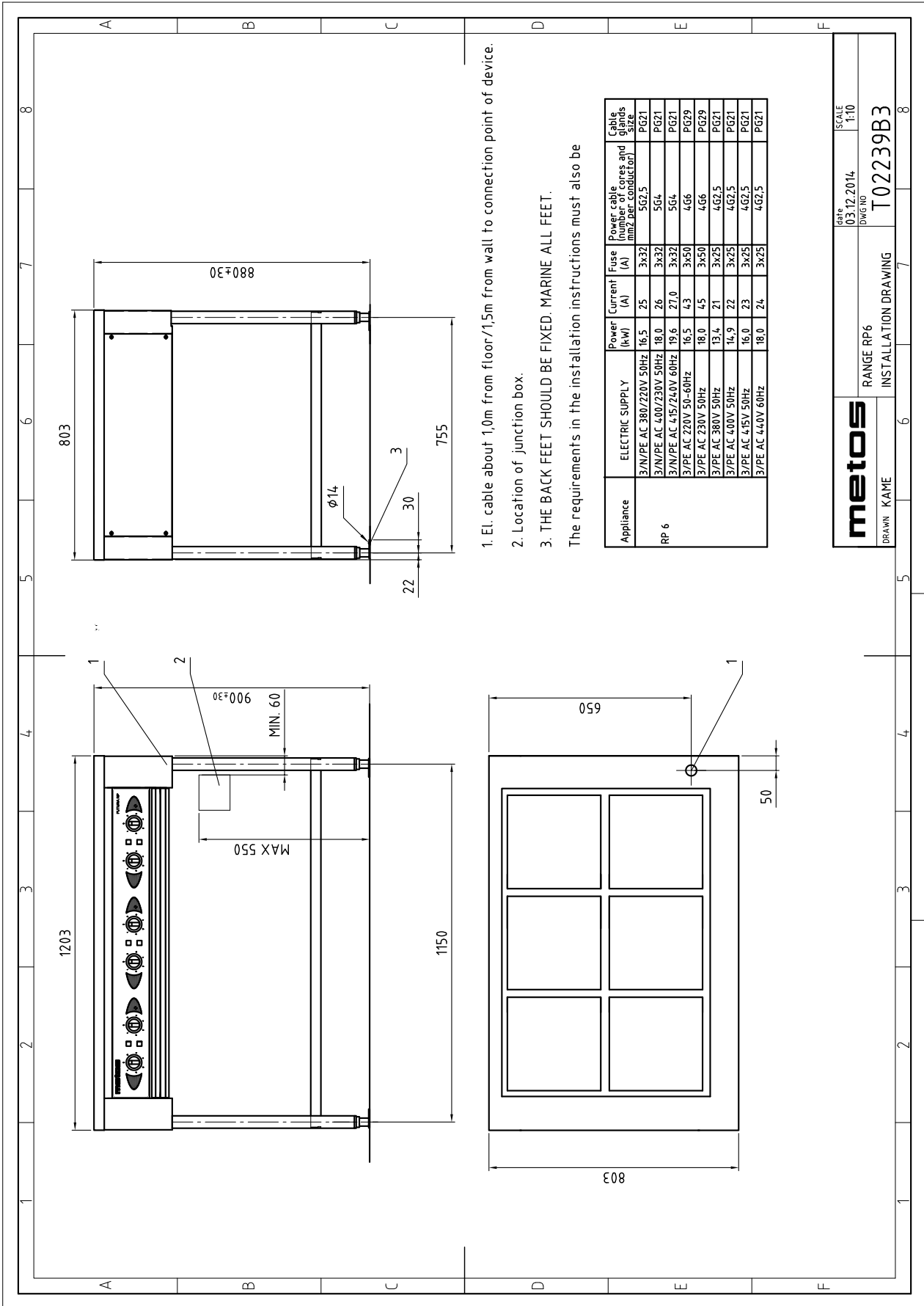

T02239B3 Installationsritning RP6

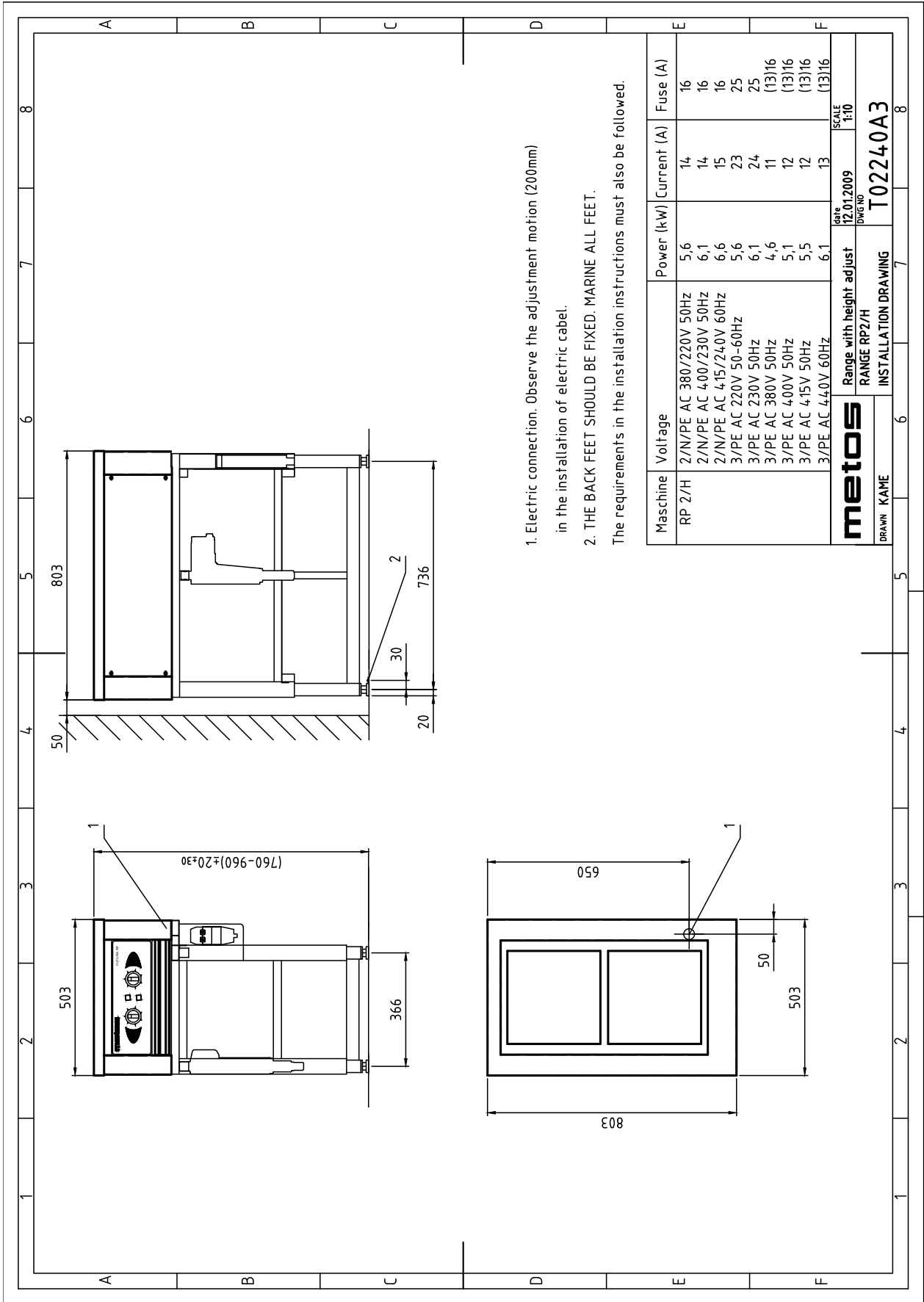

T02240A3 Installationsritning RP2 med höjdstjustering

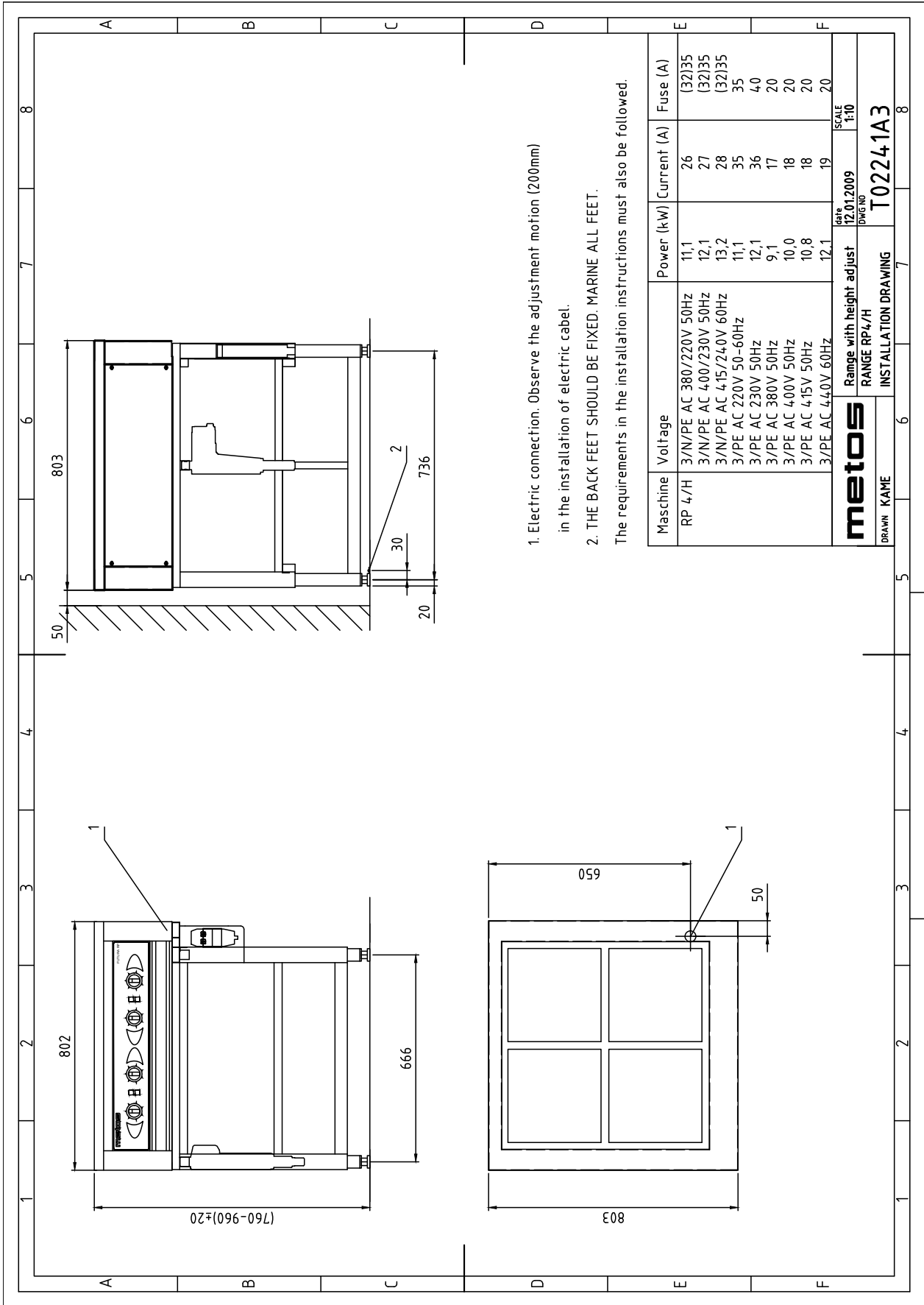

T02241A3 Installationsritning RP4 med höjdstjering

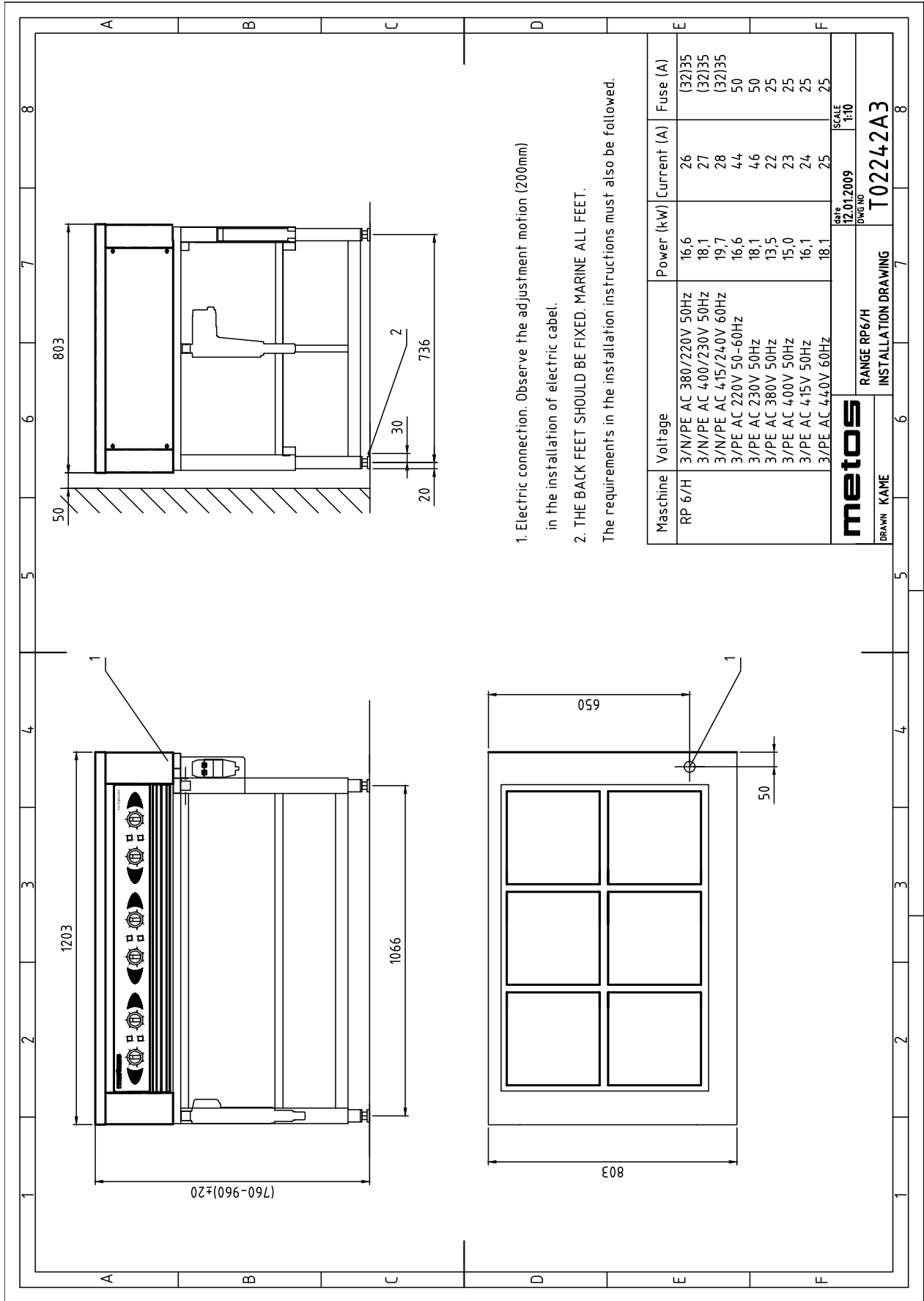

T02242A3 Installationsritning RP6 med höjdstjuring

Item	Model	Type	Access-ory	Specification
Outer dimensions WxDxH	RP	2		500 x 800 x 900 mm
Outer dimensions WxDxH	RP	4		800 x 800 x 900 mm
Outer dimensions WxDxH	RP	6		1200 x 800 x 900 mm
Cooking plates	RP	2		2
Cooking plates	RP	4		4
Cooking plates	RP	6		6
Power regulation	RP			7-position power regulator, a pilot light for each plate.
Material	RP			Cooking plates of cast iron. All outer surfaces of stainless steel
Weight with package	RP	2	ST	n. 90 kg
Weight with package	RP	2	HE	n. 105 kg
Weight with package	RP	4	ST	n. 110 kg
Weight with package	RP	4	HE	n. 130 kg
Weight with package	RP	6	ST	n. 160 kg
Weight with package	RP	6	HE	n. 185 kg
Weight without package	RP	2	ST	n. 60 kg
Weight without package	RP	2	HE	n. 75 kg
Weight without package	RP	4	ST	n. 75 kg
Weight without package	RP	4	HE	n. 95 kg
Weight without package	RP	6	ST	n. 105 kg
Weight without package	RP	6	HE	n. 130 kg
Package dimensions WxDxH		2	ST,HE	560 x 920 x 1050 mm
Package dimensions WxDxH		4		860 x 920 x 1050 mm
Package dimensions WxDxH		6		1260 x 920 x 1050 mm
Electrical connection				See installation drawing.
Operating conditions				Normal commercial kitchen conditions, temperature over 0°C.

RP=FUTURA RP
 ST=STAND, HE=HEIGHT ADJUSTMENT
 A=3/N/PE~400/230V 50Hz, H=3/PE~230V 50Hz, I=3/PE~220V 60Hz, J=3/PE~380 50Hz, L=3/PE~415V 50Hz, M=3/ PE~440V 60Hz



The crossed-out wheeled bin means that within the European Union the product must be taken to separate collection at the product end-of life. This applies to your device but also to any enhancements marked with this symbol. Do not dispose of these products as unsorted municipal waste.



Valmistajan nimi / Tillverkarens namn / Manufacturer's name

METOS OY AB

Osoite / Adress / Address

04220 KERAVA
FINLAND

Vakuuttaa, että seuraava tuote / Försäkrar att följande produkt / Declare that the following product

Nimi, tyyppi tai malli / Namn, typ eller modell / Name, type or model

Liesi / Spis / Range series **METOS FUTURA RP**

Mallit / Modeller / Models : RP2, RP4, RP6, RP4/200, RP4/220, RP4/240, RP6/200, RP6/220, RP6/240

Varusteet / Options / Options: HA2/4/6

on seuraavien direktiivien asiaankuuluvien säännösten mukainen / överensstämmer med tillämpliga bestämmelser i följande direktiv / is in conformity with the relevant provisions of the following directives

MD 2006/42/EC, LVD 2014/35/EU, EMC 2014/30/EU, RoHS 2011/65/EC, WEEE 2012/19/EU

ja lisäksi vakuuttaa, että seuraavia yhdenmukaistettuja standardeja (tai niiden osia/kohtia) on sovellettu / och försäkrar dessutom att följande harmoniserade standarder (eller delar/paragrafer) har använts / and furthermore declares that the following harmonised standards (or parts/clauses) have been used

EN ISO 12100:2010, EN ISO 13857:2019, EN 61000-6-1:2019, EN 61000-6-3,
EN 60204-1:2018

ja lisäksi vakuuttaa, että seuraavia muita standardeja (tai niiden osia/kohtia) on sovellettu / och försäkrar dessutom att följande andra standarder (eller delar/paragrafer) har använts / and furthermore we declare that the following other standards (or parts/clauses) have been used

EN 60335-1:2020, EN 60335-2-36:2017, EN 60335-2-42

Alla mainittu henkilö on valtuutettu kokoamaan teknisen tiedoston / Nedan nämnda person är bemyndigad att sammanställa den tekniska dokumentfilen / The person mentioned below is authorized to compile the technical file

Otto Miettinen Metos Oy Ab, Ahjonkaarre, 04220 Kerava, Finland

Tämä vaatimustenmukaisuusvakuutus on annettu valmistajan yksinomaisella vastuulla. Edellä kuvattu vakuutuksen kohde on unionin asiaankuuluvan yhdenmukaistamislainsäädännön vaatimusten mukainen.

Denna EU-försäkran om överensstämmelse utfärdas på tillverkarens eget ansvar. Föremålet för försäkran ovan överensstämmer med den relevanta unionslagstiftningen om harmonisering.

This declaration of conformity is issued under the sole responsibility of the manufacturer. The object of the declaration described above is in conformity with the relevant Union harmonisation legislation

Antopaikka ja päivä / Utfärdad på ort och datum / Place and date of issue

KERAVA 18.11.2022

Vakuutuksen antajan nimi ja asema / Namn och befattning av personen som försäkrar / Name and title of declaring person

Hannu Ahola – Director of Business Unit

Risto Koskelainen – R&D Manager

Manufacturer's name METOS OY AB
Address 04220 KERAVA FINLAND

Declare that the following product

Name, type or model Range series METOS FUTURA RP Models : RP2, RP4, RP6, RP4/200, RP4/220, RP4/240, RP6/200, RP6/220, RP6/240 Options: HA2/4/6
--

is in conformity with the essential requirements and other relevant requirements of the UK legislation. The products are in conformity with the relevant UK legislation

Electrical Equipment (Safety) Regulations 2016, Electromagnetic Compatibility (EMC) Regulations 2016, Machinery (Safety) Regulations 2008: Great Britain, The Restriction of the Use of Certain Hazardous Substances in Electrical and Electronic Equipment Regulations 2012, Regulations: Waste Electrical and Electronic Equipment (WEEE)

furthermore declares that the following harmonized standards (or parts/clauses) have been used

BS EN ISO 12100:2010, BS EN ISO 13857:2008, BS EN IEC 61000-6-1:2019, BS EN IEC 61000-6-3:2007, BS EN 60204-1:2018
--

and furthermore we declare that the following other standards (or parts/clauses) have been used



BS EN 60335-1:2012+A15:2021, BS EN 60335-2-42, BS EN 60335-2-36

The person mentioned below is authorized to compile the technical file

Otto Miettinen Metos Oy Ab, Ahjonkaarre, 04220 Kerava, Finland
--

This declaration of conformity is issued under the sole responsibility of the manufacturer. The object of the declaration described above is in conformity with the relevant UK legislation

Place and date of issue KERAVA 18.11.2022
--

Name and title of declaring person  Hannu Ahola – Director of Business Unit	 Risto Koskelainen – R&D Manager
--	---



Metos Oy Ab
Ahjonkaarre FI-04220 Kerava, Finland
tel. +358 204 3913
www.metos.com